

E016

Springer "Ducklin"

INFORMATION ABOUT PRODUCT

Minimum Space	380x330x234 cm
Impact Protection net	10,55 m ²
Dimensions	80x30 cm
Overall Height	84 cm
Free falling height	<60 cm
Foundations	1 pcs
Availability of spare parts	YES
Product complies with EN 1176	YES
Age range	1,5-14
Amount of users	1

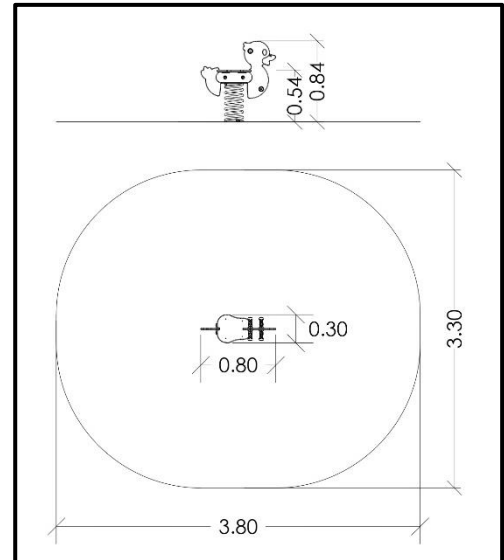

MATERIALS

- Springs: High quality spring steel according to EN10270. The springs are cleaned by phosphating before they are painted with an epoxy primer and a polyester powder coating as top finish.
- Single figure main boy: HPL 18 mm (EXT)
- Double figure main boy: HPL 12 mm (EXT)
- Seat: HPL Antiskid 12mm (EXT)
- Hand Grips / Foot Rest: Fiber reinforced plastic
- Metal Parts (colored): Hot Dip Galvanized and powder coated Steel
- Metal Parts (non - colored): Hot Dip Galvanized and / or Stainless Steel
- Fasteners: Electroplated coated or Stainless Steel (304 / 316L)
- Ground Anchors: Hot Dip Galvanized steel

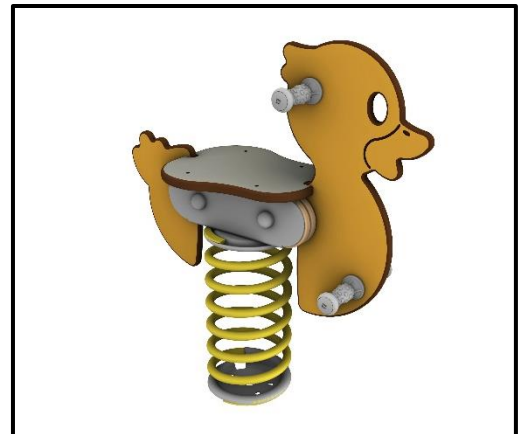

Please note that the above list of materials concerns the articles of the whole series. Therefore, some of them are not used in the described article.